

ERECTA SWITCH

Now you can sense small flows in liquid or gas lines for less than the price of a movie ticket. Series 5 products are a family of small sensors based on a common part set and principle of operation. Pressure differential across a movable magnetic poppet operates a reed switch and/or provides a visible indication of flow through a transparent window.

5-20, 5-21 and 5-21H are the key elements of the Series 5 ERECTA SWITCH product group. When combined with ERECTA accessory components, switch sets are formed providing additional features and extending application possibilities.

Although 5s are designed for small flow applications (under 3 GPM), they can be used in by-pass lines so flow can be sampled and sensed without impeding flow efficiency. As an "in the flow stream" sensor, 5s are only limited by the I.D. of their internal port diameter.

Switches are preset, at time of manufacture, to close contact upon increasing flow rate. Set points ranging from .01 GPM to 1.0 GPM are in stock so prompt shipment is not a problem. And you can choose the construction material best suited to your needs. 5s are offered in a choice of Polypropylene, Acetal or Kynar PUDF plastics. Except for the 3/8 NPT boss 5-21H switch, connections to the flow medium are made through accessory adapter fittings. Several pipe thread and hose sizes can be accommodated.

Monitoring coolant flow, activating equipment at flow turn-on, detecting flow in spray/sprinkler systems are excellent applications for this product. "Check 'em out". 5s are the affordable small flow solution.

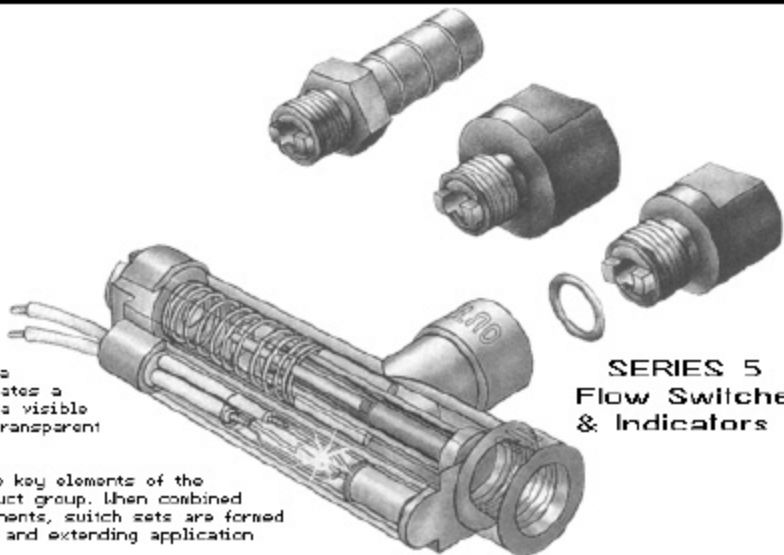

**SERIES 5
Flow Switches
& Indicators**

SERIES 5 SWITCHES (Water 20°C)	ΔP PSI @ actuation threshold				
	0.1	.25	0.5	.75	1.0
* Set Point in GPM					
5-20-□□-□□□□	.5 30	.6 30	.75 25	1.2 22	1.4 20
5-21-□□-□□□□	.22 32	.3 31	.4 30.5	.52 30	.7 30
* Set Point in GPM	—	.30	—	.75	—
5-21H-□□-□□□□	—	.5 20	—	.7 6.5	—



* + - 10% Characteristic performance.

SCHEMATIC

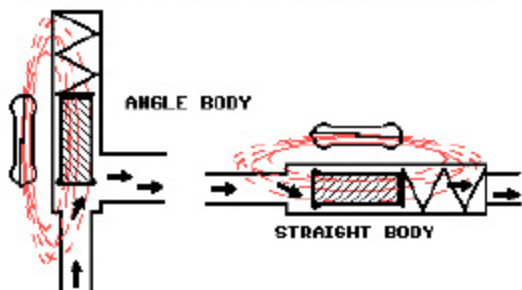
Differential pressure across magnetic poppet moves the magnet to actuate the SPST normally open switch. The switch remains closed until flow is reduced.



APPLICATION ENVIRONMENT		
Pressure	200 PSI MAX @ 20°C	Derate, Zero @ 90°C
Temperature	90°C MAX	---
Mfg Position	Any W/Spring	Vert W0/Spring
Liquid/Gas	Clear	Low Viscosity

ELECTRICAL RATING	
OKI TM 	
OKI Sensor Device Corporation	
Contact life	Complete OKI Reed Switch Datasheet available at http://www.cdcd.co.jp/
Contact rating	70 VA*, 50W* *Resistive OKI Sensor Device Corporation Reed Switch Model ORD229 Tokyo 193-8550, Japan
UL file E79063	
Max Switching Voltage	300AC, 350DC
Max Switching Current	AC 0.5AMP*, DC 0.7AMP*

MATERIALS OF CONSTRUCTION

All Models	PP	(Gray & black) Polypropylene
All Models	AC	(Red) Acetal
All Models	KR	(Natural) Kynar PVDF

SERIES 5 MODEL DIFFERENTIATION

5-20 Angle flow pattern; .1 to 1.0 GPM preset (5) trip points; clean out cap; static area above spring; poppet moves away from flow path at high flow; can operate without spring if vertically mounted; accessory thread adapters required; ERECTA SWITCH indicator trim, low flow trim, wiring receptacle and battery operated beeper available. Highest price.

5-21 Straight flow pattern; .1 to 1.0 GPM preset (5) trip points; low pressure drop at/or near threshold operate point; large pressure drop at high flow, can operate without spring if vertically mounted; accessory thread adapters required. Intermediate price.

5-21H Straight flow pattern; .30 or .75 GPM preset trip point; low pressure drop at/or near threshold operate point; comparatively lower pressure drop at high flow rate; return spring required; accessory thread adapters not required. Lowest price.

* UL component recognition applies to the OKI switch Model ORD229. Observe applicable electrical codes when using this product.

ANGLE OR STRAIGHT BODY?

Aside from the difference in flow path through the body, 5-20, 21 and 21H switches share the same internal parts. Pressure drop, sensitivity and clean out provisions are the differentiating attributes.

**DIRECT FLOW SENSING**

Liquid or gas flowing through the switch (within the limits of the product's differential pressure sensitivity and flow rate capacity) will be detected. *Installing the switch in the flow stream is direct flow sensing.* This would be the product's expected application when the flow rate is between .1 and 3 BFM. Switch is shown connected to a Button Pack SS Relay for greater load handling capacity.

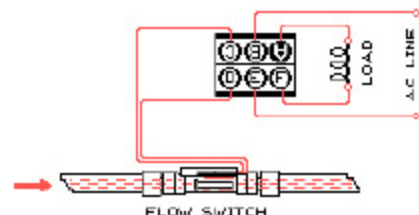
**INDIRECT FLOW SENSING**

Placing the switch in a bypass line so only a portion of the system's flow passes through it expands the range of possible applications. Any flow rate within the units pressure rating can be detected when the required pressure differential is present.

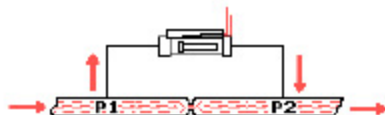
**VENTURI METER SENSING METHOD**

Among the available sensing techniques, the Venturi meter method provides the simplest way to detect the presence or absence of flow in a pipe. This method is based on the principle that different flow velocities produce different amounts of suction. The meter comprises a pipe incorporating a constriction or "waist". The velocity in the pipe just past the waist (B) is greater than the upstream area (A). The suction (lower pressure) is similarly greater in the area just past the waist. Since the difference in pressure between (A) and (B) depends upon flow velocity, it must also depend upon the quantity of fluid passing through the pipe per unit of time. (In the case of water, . . . flow rate in cubic ft/sec = cross sectional area of pipe in sq. ft. x flow velocity in ft/sec). Hence this pressure differential provides a measure for the flow rate.

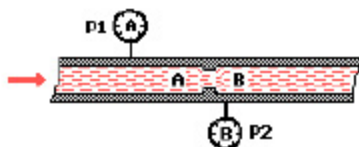

BYPASS FLOW SENSING

As the diagram shows, a small percentage of the system's flow stream is diverted through an unobstructed, close coupled bypass. Using our .1 GPM set point switch, flow, in the bypass, of less than 1 pint per minute at about 3 ounces pressure will cause switch actuation; about 1% of the flow in a 10 GPM system.

Getting the flowing medium into the bypass requires the bypass be placed across a constriction in the line so that differential pressure, sufficient to operate the switch is available in the bypass. This constriction may be part of the system's plumbing or a clogged filter or pipe. Considering the sensitivity of our switch, the constriction required is minimal, localized and the resulting pressure drop in the main stream is often insignificant. Switch is shown connected to a current limited incandescent bulb.

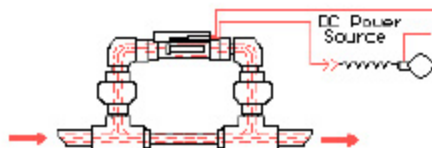

The chart below shows what can be expected when flow is sensed in a bypass connected to a 1/2" Sch 40 pipe flow stream. Here it can be seen that a constriction of as little as 7% in the flow stream is sufficient to make the bypass technique effective.

5-21 Set For 0.1 GPM Trip (Water)	Diameter Of Constriction in 1/2" Sch 40 Pipe							
	.187	.250	.312	.375	.437	.500	.562	.602
GPM Full-in	1.05	1.75	2.55	3.5	4.75	6.0	7.5	—
GPM Drop-out	1.00	1.70	2.5	3.3	4.5	5.75	7.25	—

LOW FLOW TRIM

The internal trim of the 5-20 switch can be exchanged with special trim designed to increase the ability to detect small flows. The product is sold as a set cataloged as 5-20-LF-□□-□□. Exchanging trim is a matter of discarding the standard trim (clean out cap and poppet) and replacing it with the LF trim (clean out cap, poppet and orifice). The table below shows performance with and without the return spring installed. Assuming the sensor is mounted in the "poppet up" vertical position, operating without the spring will increase detection sensitivity. This may be useful in pulsating flow applications.

ΔP PSI LIQUID	5-20-LF GPM (Water 20°C)							
Spring	—	—	2.0	3.0	5.0	10	15	20
No Spring	.5	1.0	2.0	3.0	5.0	10	15	20

ΔP PSI GAS	5-20-LF SCFM (Air 20°C)							
Spring	—	—	2.1	3.2	4.5	5.8	7.0	8.6
No Spring	.5	1.0	2.0	3.0	4.0	5.5	6.8	8.6

Outlined PSI is ΔP at switch actuation threshold.

INDICATOR TRIM

Special trim adds a visual flow indication feature to the 5-20 switch. The product is sold as the 5-19-□□-□□ indicator flow switch set. Conversion is a matter of discarding the standard trim (clean out cap and poppet) and replacing it with the Indicator trim (Indicator window and flag poppet).

ACCESSORY FITTINGS

Fittings isolate the body from torque applied to pipe threads as well as providing thread size options. For correct operation, the 5-21 straight body switch must be equipped with our fittings (at least at the outlet boss). See 5-1-□□-□□ accessory fittings.

ANGLE BODY FLOW SWITCH

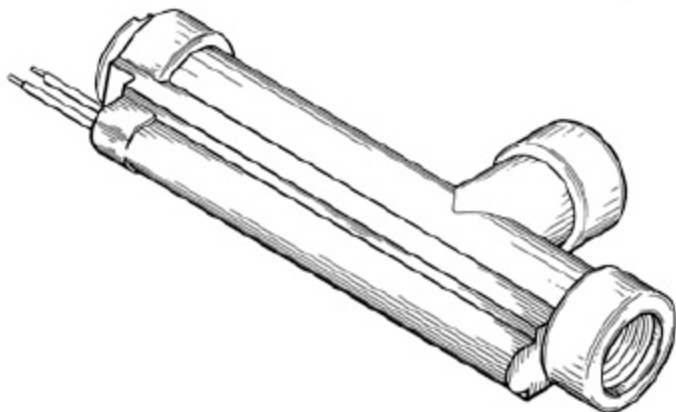
5-20--.

ORDER
FAX CLUMP # 113

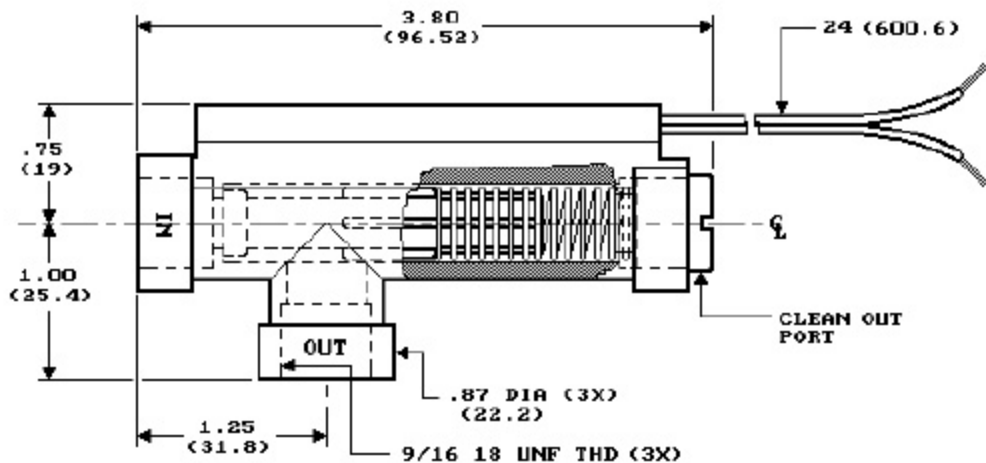

ANGLE BODY FLOW SWITCH

5-20--.

SCHEMATIC

CLOSE ON FLOW

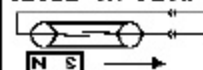

STRAIGHT BODY FLOW SWITCH

5-21-□□-□.□□

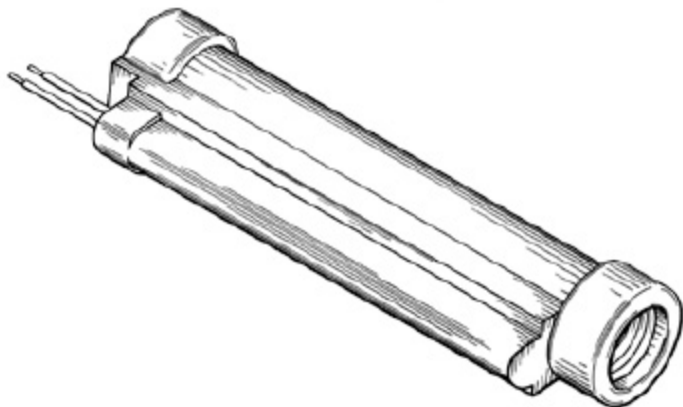
*ORDER**FAX CLUMP # 114*

STRAIGHT BODY FLOW SWITCH

5-21-□□-□.□□

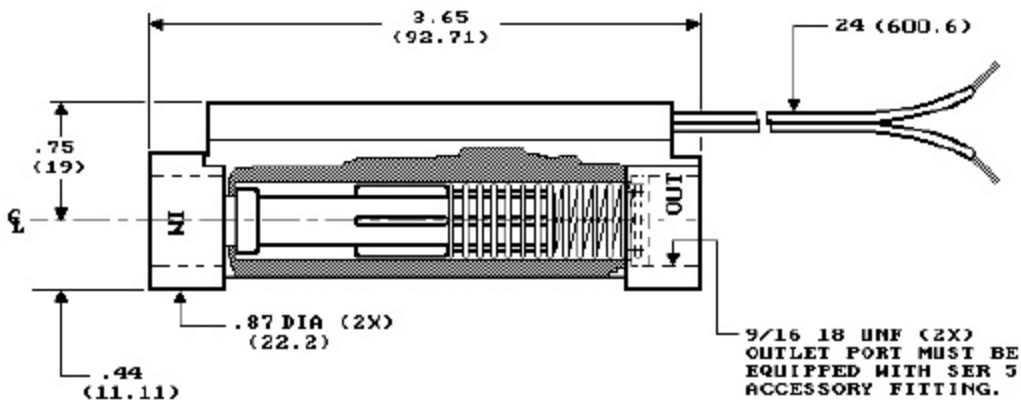

SCHEMATIC

CLOSE ON FLOW



ERECTA

SWITCH

E321AS

STRAIGHT BODY FLOW SWITCH

5-21H-□□-□□

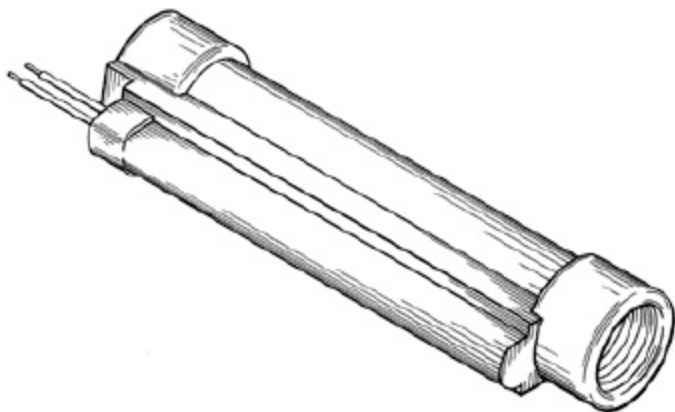
*ORDER**FAX CLUMP # 115*

STRAIGHT BODY FLOW SWITCH

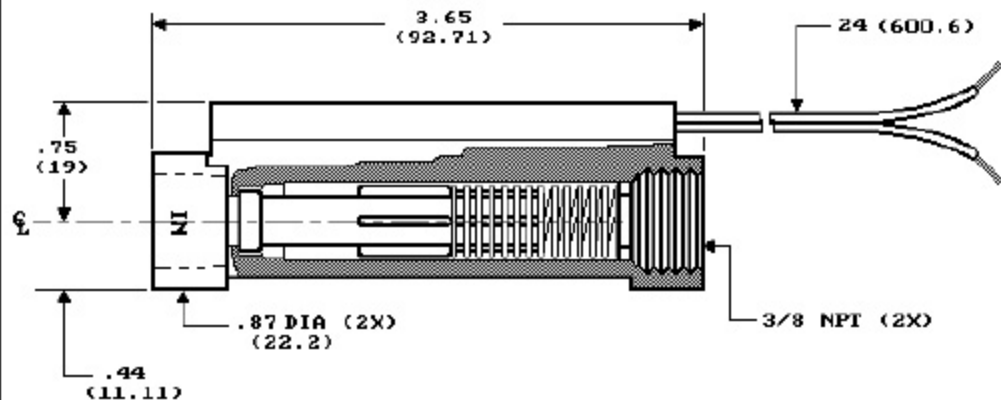
5-21H--

SCHEMATIC

CLOSE ON FLOW

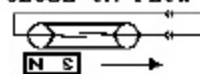

ERECTA

SWITCH

E521HAS

FLOW NO FLOW INDICATOR

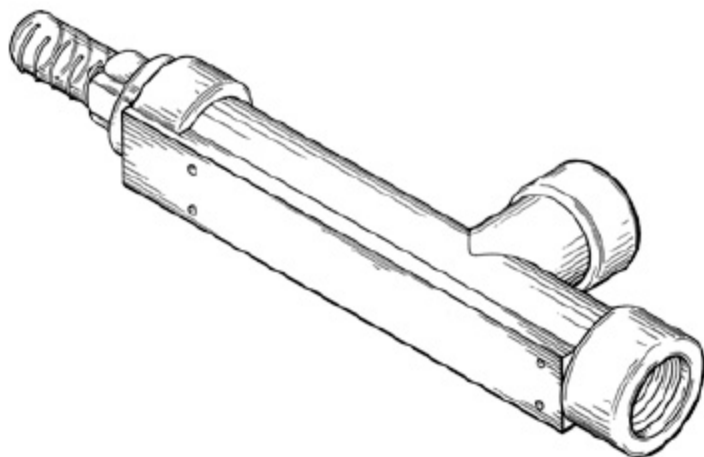
5-18-*ORDER**FAX CLUMP # 107*

INDICATOR FLOW SWITCH SET

5-19-□□-□.□□

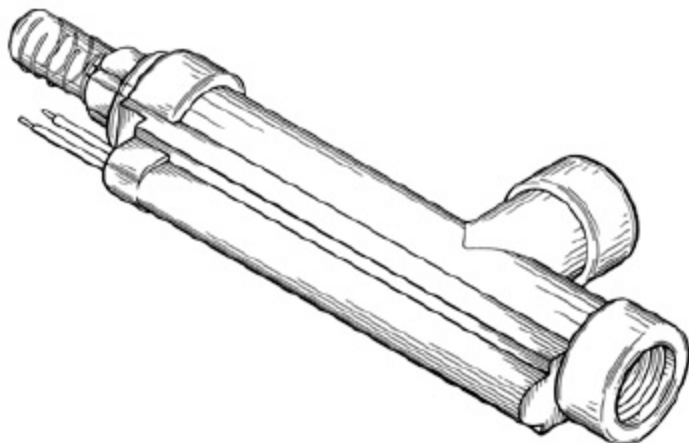

ORDER
FAX CLUMP # 108



INDICATOR FLOW SWITCH SET

5-19-□□-□.□□

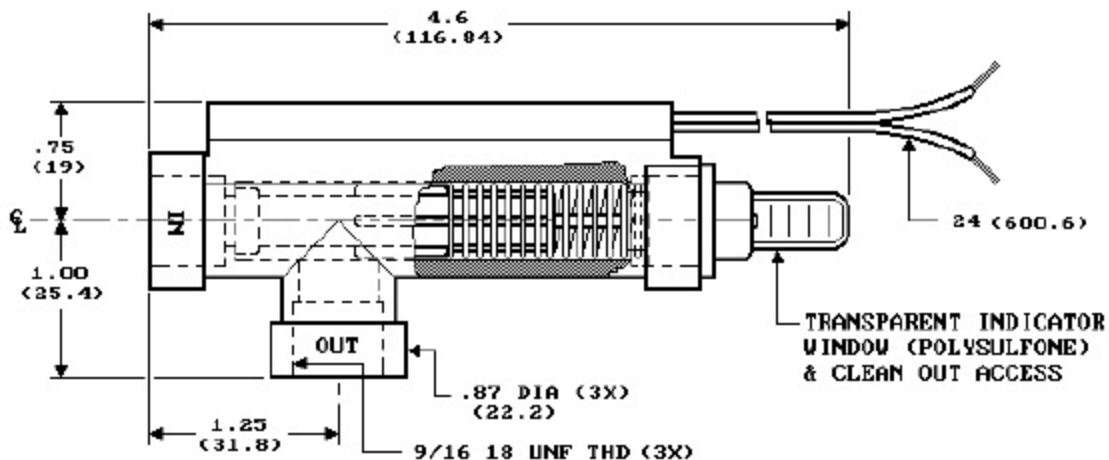

5-19-□□-□.□□ SET COMPONENTS
 5-20-□□-□.□□ FLOW SWITCH
 5-17-□□-□.□□ INDICATOR TRIM

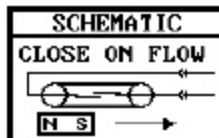

LOW FLOW SWITCH SET

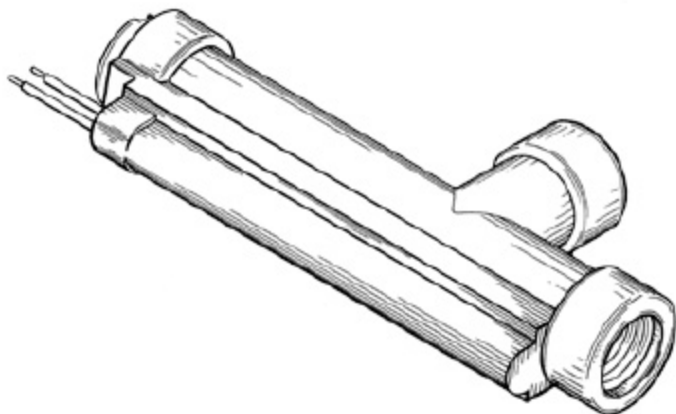
5-20-LF-

ORDER
FAX CLUMP # 109

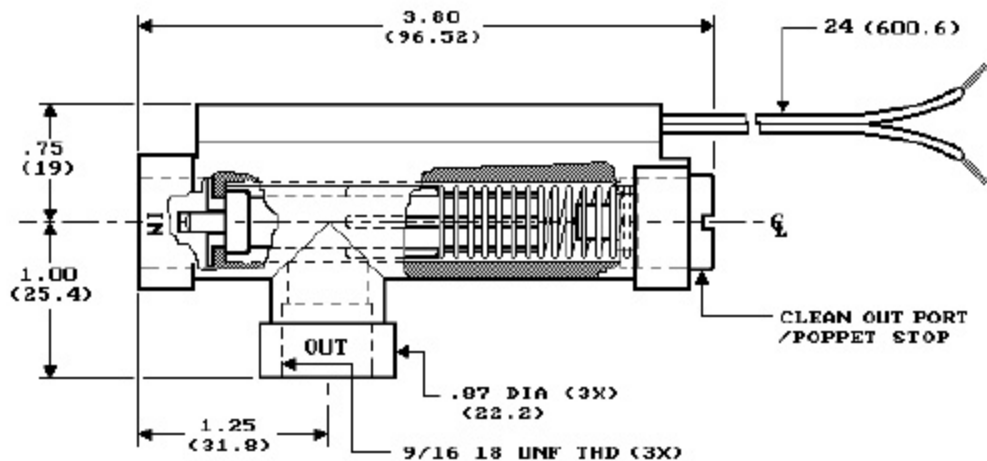

LOW FLOW SWITCH SET

5-20-LF-

5-20--LF SET COMPONENTS
 5-20--- FLOW SWITCH
 5-20-LFT- LF TRIM

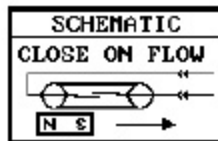

WIRE RECEPT FLOW SWITCH SET

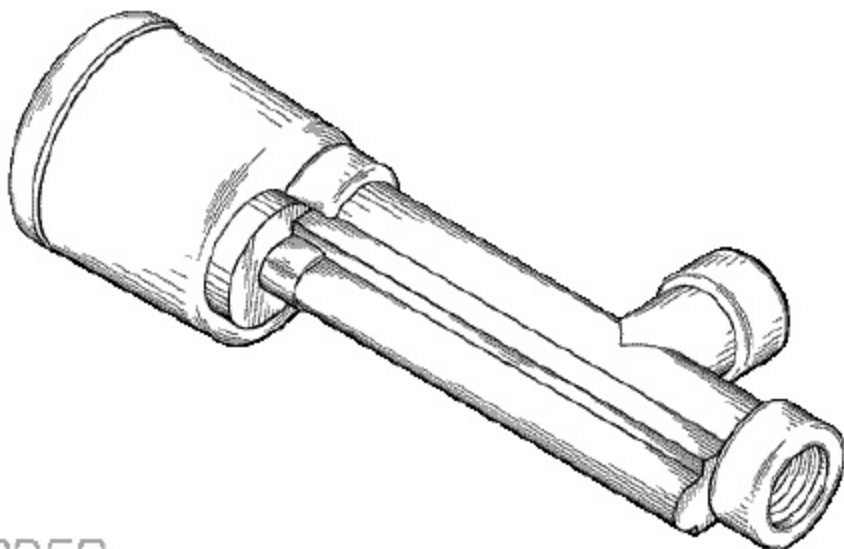
5-30--.

ORDER

FAX CLUMP # 110



FLOW SWITCH ACCESSORY FITTINGS

5-□□-1/□□

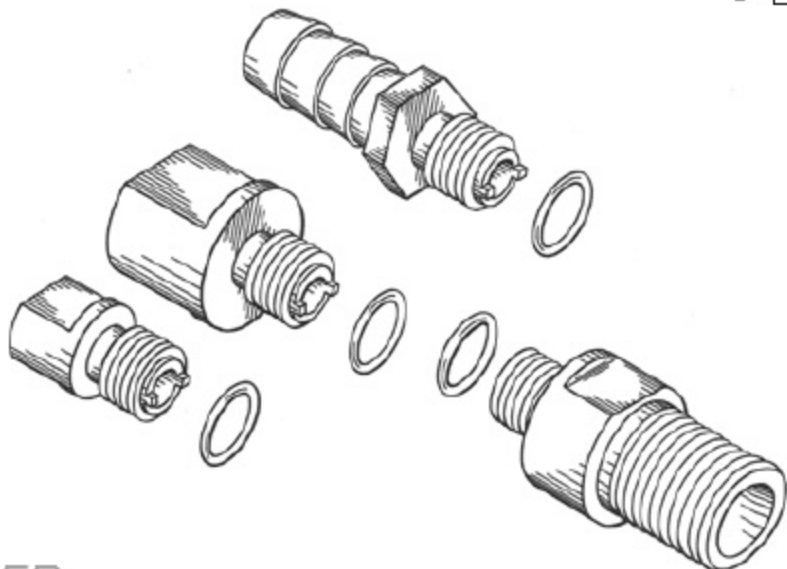

ORDER

FAX CLUMP # 112



FLOW SWITCH ACCESSORY FITTINGS

5--1/

STYLE

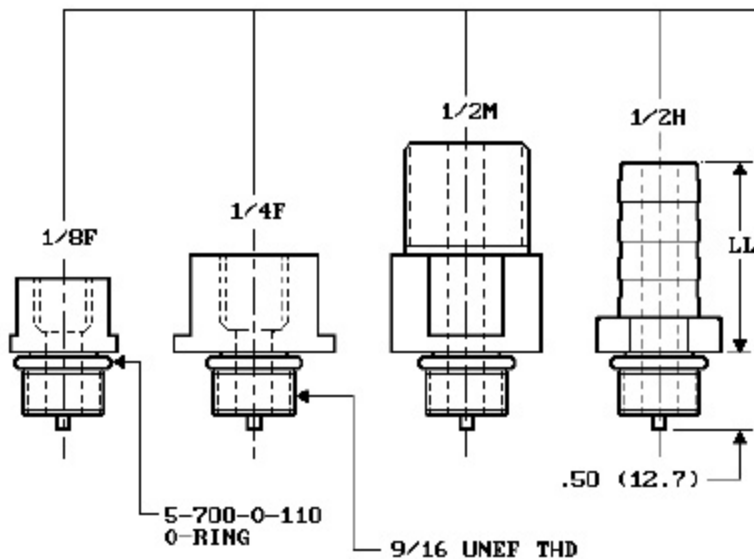

LL DIMENSION

Fitting/flow switch seal occurs at O-ring. Isolate torque applied to tapered pipe threads during installation to avoid fitting breakage.

STYLE	LL
1/8F	.50 (12.7)
1/4F	.625 (15.9)
1/2M	1.37 (34.9)
1/2H	1.25 (31.8)

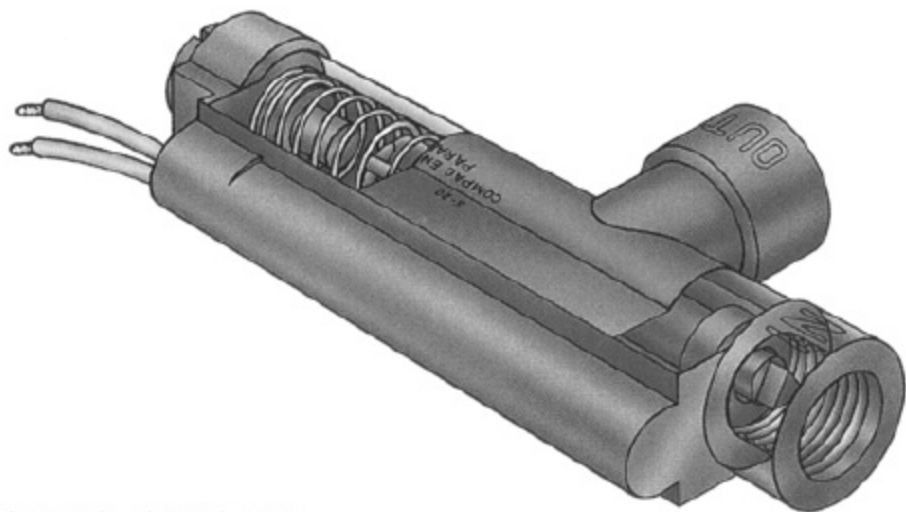

FLOW SWITCHES

**5-20 Flow Switch with LFT Flow Trim**

The ERECTA SWITCH 5-20-LFT low flow trim can be added to any 5-20 angle body flow sensing switch to convert the switch for low flow sensing as low as .01 GPM or 6 SCFM. Conversion requires exchanging poppets and end caps. The exchange can be performed in about a minute.